

LIFTWAY

EGG COLLECTION SYSTEMS

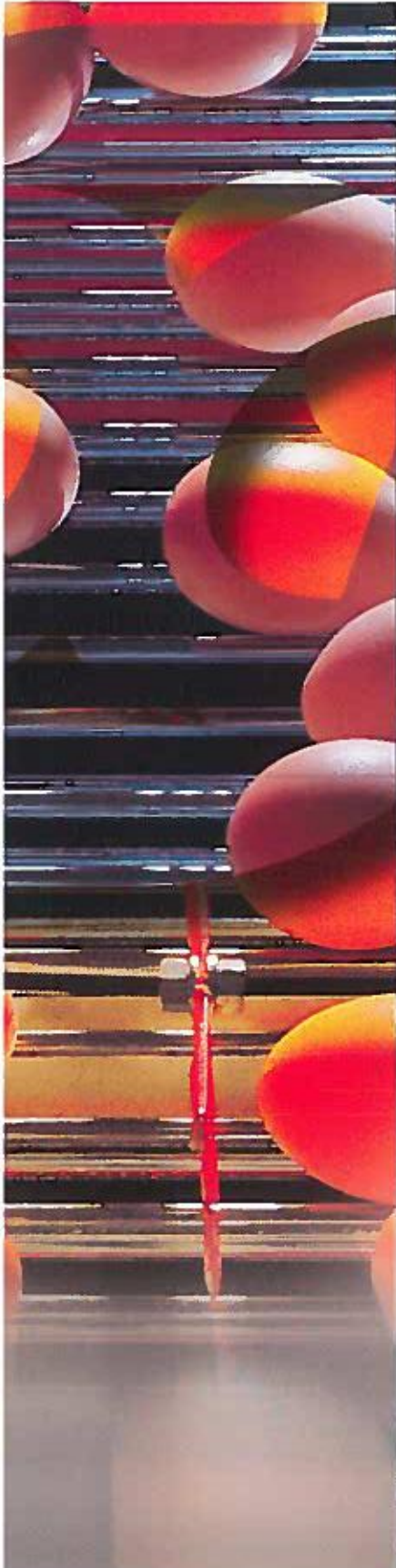

FLEXY
CONVEYORS AND AUTOMATED SYSTEMS



LIFTWAY

EGG COLLECTION SYSTEMS ...

Sistema di raccolta uova piano per piano, può essere abbinato ad una EggWay 400, 500 o 600.

La struttura è in acciaio inossidabile abbinato a particolari in alluminio e/o materiali plastici. I vantaggi principali sono:

- Libero accesso ai corridoi, poiché lo stazionamento è sempre alto
- Un solo trasferimento dell'uovo dal nastro juta al trasportatore trasversale
- Numero ridotto di motori, quindi ridotto consumo di corrente
- Facilità d'applicazione di un variatore di velocità, per "equilibrare" le doppie raccolte
- Riduzione tempi di manutenzione e pulizia

La flessibilità e le caratteristiche dei nostri sistemi permettono di abbinare 2 EggWay alla stessa struttura Lift ottenendo così un sistema nuovo denominato "Doppio lift".

Il doppio lift raccoglie le uova 2 piani per volta garantendo:

- Riduzione netta tempi di raccolta,
- Capacità di fornire grandi quantità d'uova alle macchine di lavorazione finale, sino a 90.000 uova/ora.

Ove sia richiesto, il sistema viene integrato con nostri tavoli avvolgitori e/o smistatori automatici.

System for egg collection level by level, can be combined with an EggWay 400, 500 or 600. The structure is in stainless steel combined with components in aluminium and/or plastics. The main advantages are:

- *Unrestricted access to corridors, since when not in use, the system is always parked in raised position*
- *Just one egg transfer from jute belt to transverse conveyor*
- *Fewer motors, giving lower power consumption*
- *Easy installation of a variable speed drive to "balance" double collection processes.*
- *Shorter maintenance and cleaning times.*

The flexibility and special features of our systems allow 2 EggWays to be combined with the same Lift structure, creating a new system called the Double Lift.

The Double Lift collects eggs 2 levels at a time, ensuring:

- *Clear reduction of collection times,*
- *Capacity for supplying large quantities of eggs to the final processing machines, up to 90,000 eggs/hour.*

Where required, the system is integrated with our automatic sorting and/or conveyor tables.

Giunto telescopico
Telescopic joint



Traino nastri
Belt drive unit

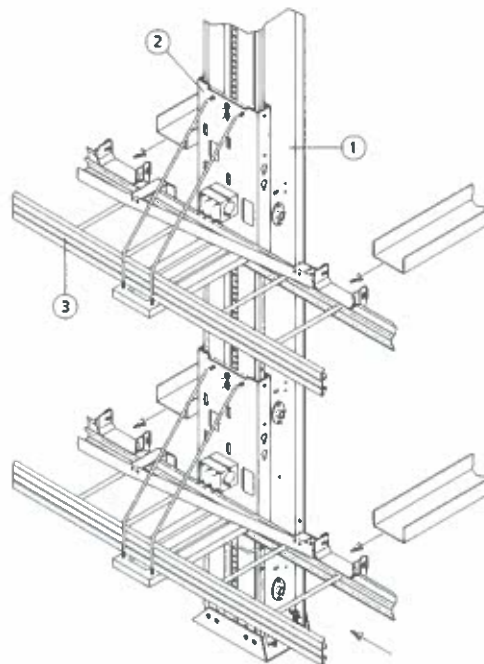

- 1 Colonna lift
- 2 Carro lift
- 3 EggWay

- 1 Lift column
- 2 Lift trolley unit
- 3 EggWay

FLEXY
CONVEYORS AND AUTOMATED SYSTEMS